

Precision target wheel

ZAx / ZFx

made of ferromagnetic steel



General

- ▶ 40 years of experience in the manufacture of precision target wheels
- ▶ Precision target wheels for attachment to shafts with a shaft diameter from 8 mm to over 500 mm
- ▶ Generation of a reference signal by reference mark (tooth or flag)
- ▶ Ferromagnetic target wheels make possible contactless magnetic scanning by a sensor with magnetoresistive sensor elements and therefore the generation of the required output signals for rotational speed and position acquisition
- ▶ Possible to manufacture target wheels for rotational speed and position acquisition using eddy currents
- ▶ Complete manufacture with bores, threads and slots

Features

- ▶ Number of teeth: 25 to 1024
- ▶ Modules: 0.3; 0.5; 1.0; 1.25; 1.50; 1.75; 2.0; 2.25
- ▶ Standard material: 16MnCr5, stainless steel optional
- ▶ Individual inside diameter optionally with feather keyway to prevent movement in relation to the shaft

Advantages

- ▶ Number mounting variants (shrinking, clamping, bolting in place mounting)
- ▶ Possible to prevent movement in relation to the shaft using feather keyway
- ▶ Multifunctional design makes it possible to use the target wheel as a bearing cover or shaft nut
- ▶ High design flexibility due to custom manufacture
- ▶ Highest precision due to usage of the latest hobbing machines or turning-milling centres

Field of application

- ▶ Machine tool engineering
- ▶ Railway rolling stock
- ▶ Torque motors

Description

Measuring systems

For the measurement of rotary movements, rotational speed and position sensors form a unit together with target wheels. Especially on spindles for machine tools, the sinusoidal output signals are highly interpolated. To obtain optimal output signals, target wheels must be manufactured with high precision for this application. Only in this way can the output signals from the sensors be generated in the necessary quality.

High precision standard target wheels made of ferromagnetic steel with module 0.3, 0.5 and 1 are available ex-works on short delivery times.

Usage with MiniCoder

GEL 2442, 2443, 2444 and 2432

MiniCoders scan target wheels with module 0.3; 0.5 or 1. Square-wave signals with 5 V DC, 10...30 V DC or 1 V_{pp} signals (sin/ cos-shaped track signals) are generated as output signals.

The target wheels are optionally equipped with a reference flag, a reference groove or a reference tooth. Depending on the version or position of the reference mark, a different MiniCoder variant is used to ensure a defined position for the reference signal in relation to the track signals.

Maximum rotational speed

Size, inside diameter and design of the target wheel define the strength and the maximum permitted rotational speed. In your enquiries please state the maximum rotational speed at which the related target wheel is to be used. We will then assess the feasibility.

In certain cases we undertake calculations using the FEM⁽¹⁾.

Typical rotational speed range for target wheels as a function of the inside diameter and reference mark

Number of teeth z	Module m	Inside diameter d _i [mm]	Outside diameter d _a [mm]	Reference mark, reference signal	Maximum rotational speed ^(a) n _{max} [1/min]
64	0.5	23	33	Z	90,000
64	0.3	10	19.8	Z	140,000
128	0.3	20	39	N	30,000
128	0.3	17	39	M	42,000
256	0.3	12	77.8	Z	50,000
256	0.3	50	77.8	Z	40,000
512	0.3	20	154.2	Z	18,000
512	0.3	125	154.2	Z	25,000

^(a) Bores, thread, feather keyways not taken into account

Module and outside diameter

Depending on the application and sensor used, target wheels with different modules are used.

The module is a tooth parameter for tooth wheels and describes the relationship between the number of teeth and the pitch circle diameter of the tooth wheel.

For the majority of applications the amount of space available is limited, here the outside diameter is crucial.

The following applies:

$$d_a = m \cdot (z+2)$$

d_a = Outside diameter

m = Module

z = Number of teeth

Given the same number of teeth, the smaller the module the smaller outside diameter.

⁽¹⁾ Finite Element Method

Reference marks

Reference marks can be designed as a tooth, groove or flag. The flag must be made of ferromagnetic material and must not protrude beyond the tip circle of the target wheel.

The selection of the reference mark is defined by the size and rotational speed of the target wheel used, as both parameters have an effect on the forces acting on the reference mark. In case of new designs we recommend the usage of a target wheel with reference mark variant "Z".

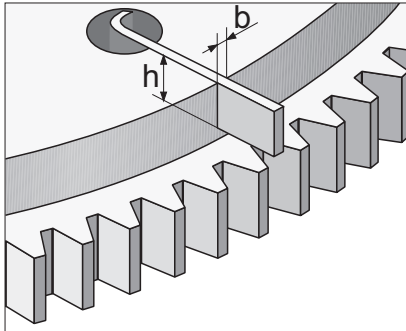

ZAN / ZFN = Reference mark – flag

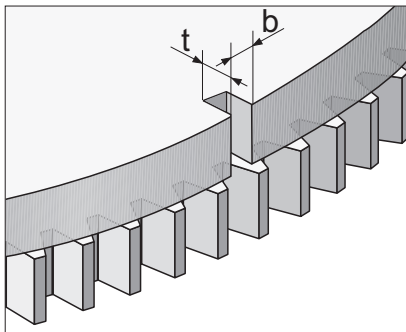

ZFM = Reference mark – groove

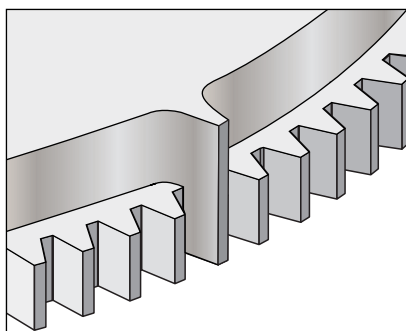

ZAZ / ZFZ = Reference mark – tooth

Identifier

Depending on the reference mark, target wheels have the following item numbers as identifiers:

Standard target wheels

- ZANxxxx** Reference mark as flag (reference flag is between two teeth)
- ZAZxxxx** Reference mark as tooth (reference tooth is aligned with a tooth)

Custom target wheels

- ZFNxxxx** Reference mark as flag (reference flag is between two teeth)
- ZFMxxxx** Reference mark as groove (reference groove is between two teeth)
- ZFZxxxx** Reference mark as tooth (reference tooth is aligned with a tooth)

The target wheels are marked with item number and serial number.

Example	
ZFN1027.0	Custom target wheel (ZF) with reference flag (N), tooth wheel number: 1027, drawing status index 0
11/07/000456	Year/ month/ sequential number

Standard target wheels

Available ex-works on short delivery times

Type code

ZA	Reference mark	
	N	with reference mark flag, located between two teeth
	Z	with reference mark tooth, aligned with a tooth
	-	without reference mark
	Module	
3	Module 0.3	
5	Module 0.5	
1	Module 1.0	
Number of teeth		
---	see table "design of standard target wheels "	
Inside diameter		
---	see table "design of standard target wheels "	

Dimensional drawing standard target wheels with reference mark tooth – ZAZ

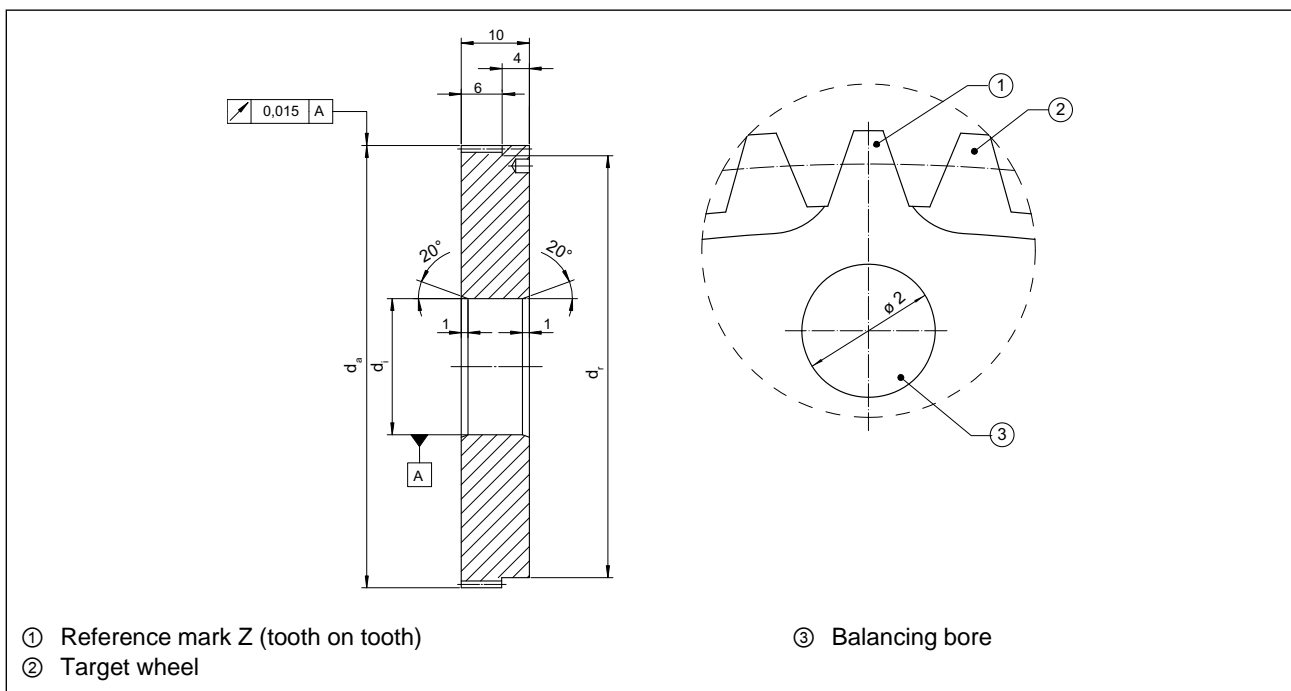

Design of standard target wheels ZAZ

Number of teeth z	Module m [mm]	Outside \varnothing da [mm]	Inside \varnothing di min [mm]	Inside \varnothing di max. [mm]	Shoulder \varnothing dr [mm]
100	0.5	51.0	12 H7	30 H7	48
125	0.5	63.5	12 H7	40 H7	60.5
128	0.5	65.0	12 H7	40 H7	62
200	0.5	101	12 H7	70 H7	98
256	0.5	129	12 H7	90 H7	126
250	0.3	75.6	12 H7	45 H7	72.6
256	0.3	77.4	12 H7	50 H7	74.4
360	0.3	108.6	12 H7	70 H7	105

\varnothing - diameter

Standard target wheels

Available ex-works on short delivery times

Dimensional drawing standard target wheels with reference mark flag – ZAN

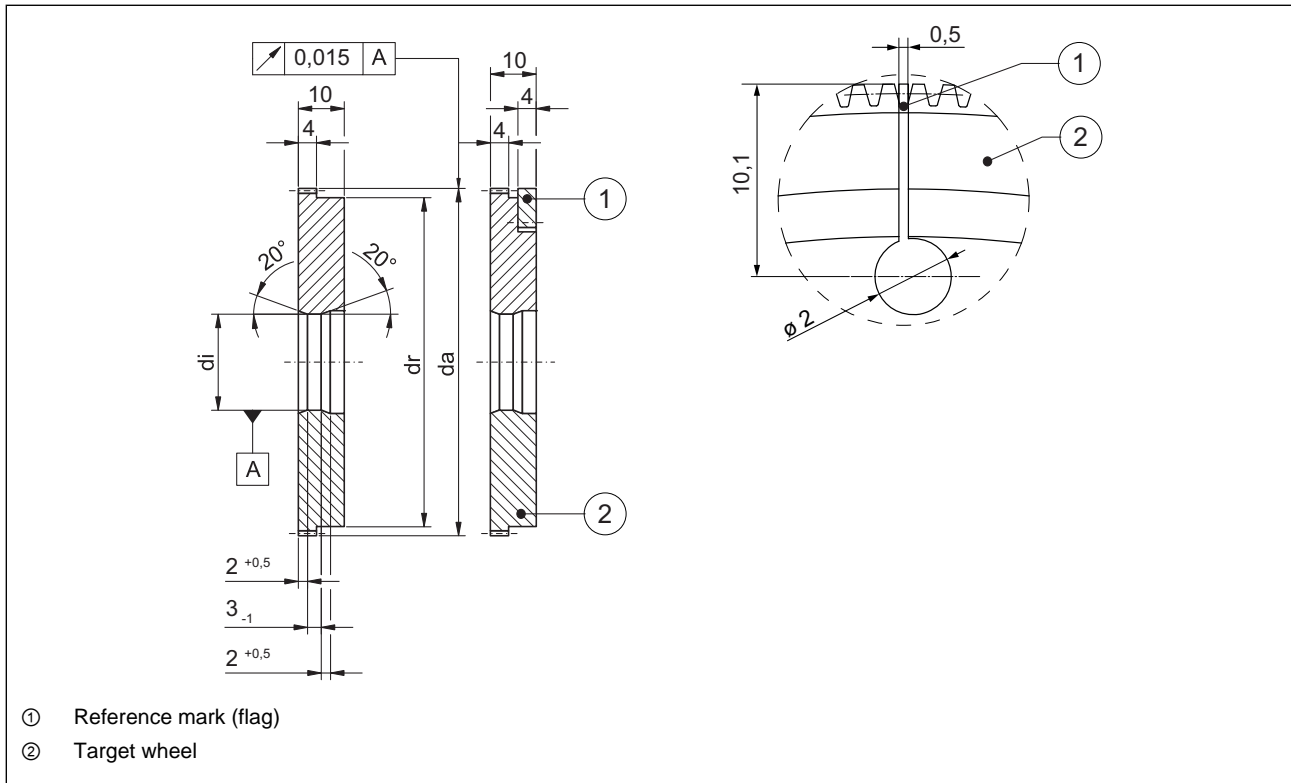

Design of standard target wheels ZAN

Number of teeth z	Module m [mm]	Outside ø da [mm]	Inside ø standard [mm]	Inside ø di max. [mm]	Shoulder ø dr [mm]
100	0.5	51.0	12 H7	30 H7	47
125	0.5	63.5	12 H7	40 H7	60
128	0.5	65.0	12 H7	40 H7	61
200	0.5	101.0	12 H7	70 H7	97
250	0.3	75.6	12 H7	45 H7	72
250	0.5	126.0	25 H7	85 H7	122
256	0.3	77.4	12 H7	50 H7	74
256	0.5	129.0	25 H7	90 H7	125
360	0.3	108.6	25 H7	70 H7	105
500	0.3	150.6	25 H7	110 H7	147
512	0.3	154.2	25 H7	110 H7	151

ø - diameter

Custom target wheels

Upon customer request Lenord + Bauer will manufacture your target wheels to your specific requirements. Please send us a design drawing of your target wheel (if possible as a dxf file) to info@lenord.de.

Shrinking

With this method the target wheel is not manufactured to exactly fit the shaft, instead the inside diameter is made slightly smaller. The target wheel cannot be fitted to the shaft at normal temperatures. By heating the target wheel the material expands and can be pushed onto the shaft. As the target wheel cools it shrinks and is pressed firmly onto the shaft.

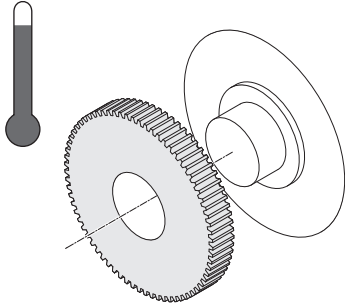

Bolting to shaft shoulder

The target wheel is pushed onto the shaft and fastened to the shaft shoulder using screws.

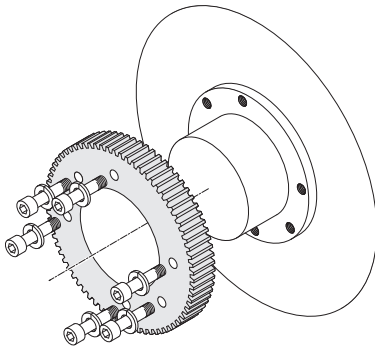

Clamping via shaft nut

The target wheel is pushed onto the shaft and pressed against this component using a shaft nut. Upon request the target wheel can also be equipped with an integrated shaft nut, for this purpose a corresponding thread is cut on the inside diameter.

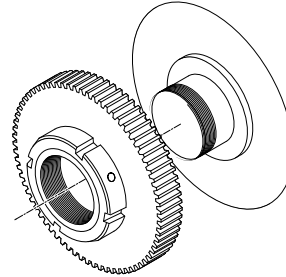

Prevention of movement in relation to the shaft

For special applications feather keyways on the inside diameter of the target wheel provide protection against twisting.

We have agencies in:

Austria
Belgium
Canada
China
Czech Republic
Denmark
Finland
France
Germany
Great Britain
Israel
Italy
Korea
Malaysia
Netherlands
Norway
Portugal
Sweden
Switzerland
Spain
Turkey
USA



Lenord, Bauer & Co. GmbH
Dohlenstraße 32
46145 Oberhausen, Deutschland
Phone: +49 208 9963-0
Fax: +49 208 676292
Internet: www.lenord.de
E-Mail: info@lenord.de

Subject to technical modifications and typographical errors.
The latest version can be downloaded at www.lenord.de.

