

CX-Series Circuit Breaker

The CX-Series circuit breaker features a unique and innovative arc-quenching configuration that allows the breaker to safely handle high amperage and high DC voltage applications in a compact package.

By using a patent pending magnetic flux boosting terminal configuration, a strong magnetic field is created thus motivating the arc into an enhanced arc chamber improving the breaker's overall performance and reliability.

The permanent magnets located at the entrance of the arc chamber combined with the upper and lower arc runner increase the magnetic blow out force and aid in motivating the arc off of the contacts and into the arc chamber.

An enhanced arc chamber features arc splitter retainers with integrated pressurizing walls, which facilitates heat transfer from the arc thereby providing additional cooling and quick transition into the magnetically induced splitter plates. In turn, the twelve (12) splitter plates attract, segment and cool the arc for full extinction.

Combined, these innovative features make the CX-Series breaker the best in class, providing stable performance even in the most demanding applications.

Applications:

- ♦ The CX-Series is UL 489B approved and ideal for integration into the combiner box or main disconnect of photovoltaic renewable energy systems.
- ♦ Ideally suitable for integration into Information Technologies' power distribution equipment utilizing high DC voltage input.



Additional Features:

- ♦ UL 489B approved
- ♦ TUV Certified IEC/EN 60947-2
- ♦ Temperature stable hydraulic/magnetic overcurrent sensing technology.
- ♦ Optional relay trip circuit permitting remote operator system shut down.
- ♦ Choice of 6-32 or M3 mounting inserts providing secure panel mount installation.



Carling Technologies™
Innovative Designs. Powerful Solutions.

Carling Technologies, Inc.
60 Johnson Avenue • Plainville, CT 06062-1177
Phone: (860) 793-9281 • Fax: (860) 793-9231
Email: sales@carlingtech.com • www.carlingtech.com

CX-Series Circuit Breaker

DESIGN FEATURES

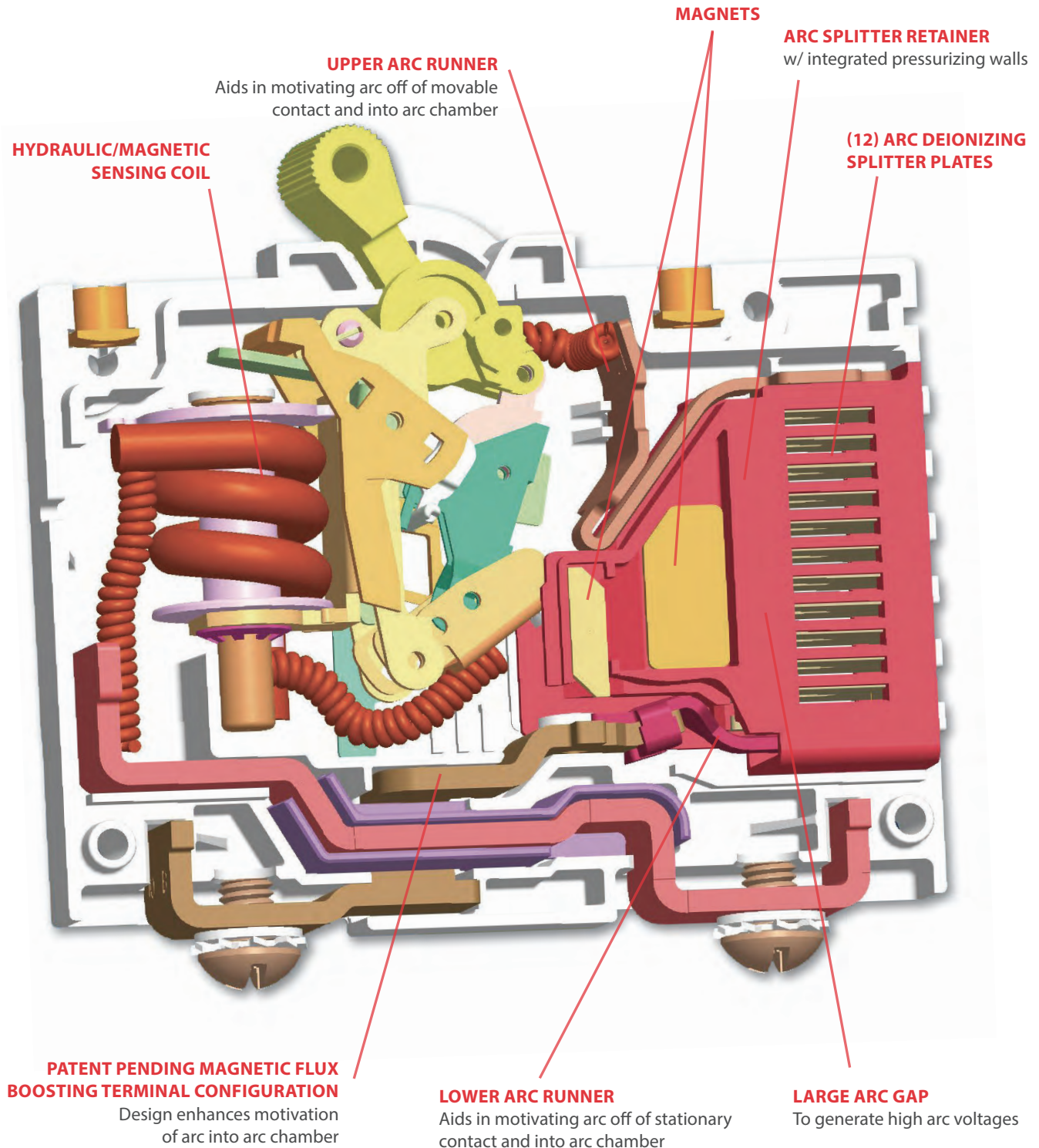

Electrical Tables

Table A: Lists UL Listed (UL489) configuration and performance capabilities as a Molded Case Circuit Breaker

CX SERIES TABLE A : UL489 LISTED BRANCH CIRCUIT BREAKERS					
CIRCUIT CONFIGURATION	VOLTAGE		MAX CURRENT RATING AMPS	INTERRUPTING CAPACITY (AMPS)	NUMBER OF POLES
	MAX. RATING	FREQUENCY			
SERIES	250	D.C.	15	5,000	1
	250 / 500	D.C.	15	10,000	2

Table B: Lists UL Recognized configurations and performance capabilities as a Component Supplementary Protector

CX SERIES TABLE B : UL1077 COMPONENT SUPPLEMENTARY PROTECTOR						
CIRCUIT CONFIGURATION	VOLTAGE		MAX CURRENT RATING AMPS	INTERRUPTING CAPACITY (AMPS)	NUMBER OF POLES	APPLICATION CODE
	MAX. RATING	FREQUENCY				
SERIES	300	D.C.	1 - 75	5,000	1	TC1, OL0, U3
	300	D.C.	76 - 125	3,000	1	TC1, OL0, U3
	440	D.C.	1 -30	10,000	2	TC1, OL0, U3
	440	D.C.	31 - 63	5,000	2	TC1, OL0, U3
	600	D.C.	1 - 75	3,000	2	TC1, OL0, U3
	600	D.C.	76 - 100	5,000	2	TC1, OL0, U3
SWITCH ONLY ¹	600	D.C.	1 - 100	3,000	2 or 3	---

Notes:

1 Requires inclusion of a relay trip voltage coil

Table C: Lists UL Listed (UL489B) configuration and performance capabilities as a Molded Case Switch

CX SERIES TABLE C : UL489B LISTED PHOTOVATIC MOLDED CASE SWITCH						
CIRCUIT CONFIGURATION	VOLTAGE			CURRENT RATING (AMPS)	INTERRUPTING RATING (AMPS)	CONSTRUCTION NOTES
	MAX RATING	FREQUENCY	POLES			
SERIES	600	DC	2 ¹	50 - 100	600	May have a third pole that is a voltage trip pole
	600	DC	4 ²	110 - 175	600	May have a fifth pole that is a voltage trip pole

Notes:

1 Two poles in series.

2 Two poles in series in parallel with 2 poles in series.

Table D: TUV Certified Configuration to IEC / EN 60947-2. Low Voltage Switchgear and Controlgear - Circuit Breakers

CX-SERIES TABLE D : TUV IEC/EN 60947-2 LOW VOLTAGE SWITCH GEAR & CONTROL GEAR / CIRCUIT BREAKER					
CIRCUIT CONFIGURATION	VOLTAGE			CURRENT RATING (AMPS)	INTERRUPTING CAPACITY
	MAX. RATING	FREQUENCY	POLES		ICS / ICU (AMPS)
SERIES	440	DC	2	1-63	4,000

*Manufacturer reserves the right to change product specification without prior notice.

Electrical

Maximum Voltage
Overload

600 VDC
50 operations at 600% of rated current for UL489, and at 150% of rated current for UL1077.

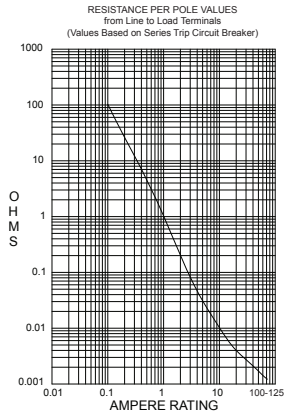

Current (amps)	Tolerance (%)
0.1 -5.0	15%
5.1-20.0	25%
20.1-125	35%

Physical

Number of Poles
Termination
Termination Barrier
Mounting
Actuator
Internal Circuit Config.
Materials
Weight
Standard Color

1- 2 poles, + Auxiliary Switch Pole.
10-32 or M5 Screw Terminals
1/4-20 or M6 Threaded Stud Terminals
Standard with multi-pole constructions
Threaded insert: #6-32 UNC-2B, or M3X0.5-6H B ISO (2 per pole)
Handle, 1 per pole.
Series Trip
Housing - Glass filled Polyester
Handle - Glass filled Polyester
Line/Load Terminals - Copper Alloy.
~150 Grams (~5.3 Ounces).
~150 Grams (~5.3 Ounces).
Housing - Gray.
Handle - White, Black, Red, Green, Blue, Yellow, Gray,

Mechanical

Endurance
Trip Free
Trip Indication

Max 10,000 ON-OFF operations @ 6 per minute; 6000 with rated current & voltage, and 4,000 cycles mechanical.
Trips on overload even when actuator is forcibly held in the "On" position.
The operating handle moves positively to the "Off" position when an overload causes the breaker to trip.

Environmental

Shock
Vibration
Moisture Resistance
Salt Spray
Thermal Shock
Operating Temperature

Withstands 100 Gs, 6ms saw tooth while carrying rated current per MIL-PRF-55629 and MIL-STD-202G, Method 213G, Test Condition "1". Instantaneous and ultra short curves tested at 90% of rated current
Withstands 0.060" excursion from 10-55 Hz & 10 Gs 55-500 Hz, at rated current per MIL-PRF-55629 and MIL-STD-202G, Method 240D, Test Cond. A. Instantaneous & ultrashort curves tested at 90% of rated current.
MIL-PRF-55629 and MIL-STD-202G, Method 106G, i.e., Ten 24-hour cycles at +25°C to +65°C, 80-98% RH.
Method 101, Condition A (90-95% RH at 5% NaCl Solution, 96 hrs).
MIL-PRF-55629 and MIL-STD-202G, Method 107G, Condition A (5-cycles at -55°C to +25°C to +85°C to +25°C).
-40°C to +85°C.

*Manufacturer reserves the right to change product specification without prior notice.



1 SERIES
C

2 ACTUATOR
X Handle, one per pole

3 POLES^{1,2}
2 Two **4** Four
3 Three **5** Five

4 CIRCUIT
S Switch Only

5 RELAY TRIP VOLTAGE COIL RATING^{1,2}
0 w/o Relay Trip Voltage Coil
A 12 VDC
B 24 VDC
C 32 VDC
D 48 VDC

6 FREQUENCY & DELAY
03 DC Switch Only

7 CURRENT RATING (AMPERES)^{1,3}

2-Pole Section		4-Pole Section	
650	50.00	811	110.00
↓		↓	
810	100.00	917	175.00

8 TERMINAL^{4,5}
3 Stud, 1/4-20
6 Stud, M6
A Stud, 1/4-20, w/ 10-32 Screw Terminals on Voltage Pole
B Stud, M6, w/ M5 Screw Terminals on Voltage Pole

9 HANDLE COLOR & LEGEND

Actuator Color	I-O	ON-OFF	Dual	Legend Color
White	A	B	1	Black
Black	C	D	2	White
Red	F	G	3	White
Green	H	J	4	White
Blue	K	L	5	White
Yellow	M	N	6	Black
Gray	P	Q	7	Black
Orange	R	S	8	Black

10 MOUNTING INSERTS
A 6-32 Thread **B** M3 Thread

11 MAX. APPLICATION RATING
06 600VDC

12 AGENCY APPROVAL
A Without approvals
14 UL489B Listed

- Notes:
- 2 Pole Unit is required for ratings between 50A - 100A.
 4 Pole Unit is required for ratings between 110A - 175A.
 - A Relay Trip Voltage Coil Pole may be added to either the 2 or 4 Pole construction. The addition of this extra pole dictates a change in the designation for the number of poles in selection 3.
 - For Current Ratings between 50A - 100A select current code 810 (100A).
 For Current Ratings between 101A - 175A select current code 917 (175A).
 - Voltage Pole must have screw terminals.
 Switch Pole must have stud terminals.
 - On 3 Pole Unit, Voltage Pole to be located at P1 as standard.
 On 5 Pole Unit, Voltage Pole to be located at P3 as standard.



1 SERIES
C

2 ACTUATOR
X Handle, one per pole

3 POLES
1 One
2 Two
3 Three

4 CIRCUIT
A¹ Switch Only (no coil)
B Series Trip (current)
G¹ Relay Trip (voltage)

5 AUXILIARY SWITCH
0 w/o Aux Switch³

6 FREQUENCY & DELAY
03 DC 50/60Hz, Switch Only
10 DC Instantaneous
11 DC Ultra Short
12 DC Short
14 DC Medium
16 DC Long

7⁶ CURRENT RATING (AMPERES)

CODE	AMPERES				
220	0.200	420	2.000	611	11.000
225	0.250	522	2.250	711	11.500
230	0.300	425	2.500	612	12.000
235	0.350	527	2.750	712	12.500
240	0.400	430	3.000	613	13.000
245	0.450	435	3.500	614	14.000
250	0.500	440	4.000	615	15.000
255	0.550	445	4.500	616	16.000
260	0.600	450	5.000	617	17.000
265	0.650	455	5.500	618	18.000
270	0.700	460	6.000	620	20.000
275	0.750	465	6.500	622	22.000
280	0.800	470	7.000	624	24.000
285	0.850	475	7.500	625	25.000
290	0.900	480	8.000	630	30.000
295	0.950	485	8.500	635	35.000
410	1.000	490	9.000	640	40.000
512	1.250	495	9.500	650	50.000
415	1.500	610	10.000	660	60.000
517	1.750	710	10.500	665	65.000
				670	70.000
				675	75.000
				680	80.000
				685	85.000
				690	90.000
				695	95.000
				810	100.000
				911	115.000
				912	125.000

8 TERMINAL
2 Screw Terminal, 10-32
3 Stud, 1/4-20
5 Screw Terminal, M5
6 Stud, M6

9 ACTUATOR COLOR & LEGEND

Actuator Color	I-O	ON-OFF	Dual	Legend Color
White	A	B	1	Black
Black	C	D	2	White
Red	F	G	3	White
Green	H	J	4	White
Blue	K	L	5	White
Yellow	M	N	6	Black
Gray	P	Q	7	Black
Orange	R	S	8	Black

10 MOUNTING INSERTS
A 6-32 Thread w/o terminal bus
B M3 Thread w/o terminal bus

11 MAX. APPLICATION RATING
10 300VDC
11⁴ 440 VDC without factory installed terminal bus
14⁴ 440VDC with factory installed terminal bus
06⁵ 600VDC

12 AGENCY APPROVAL
A Without approvals
C UL 1077 Recognized
W UL 1077 Recognized & TUV Certified IEC/ EN 60947-2⁹

- Notes:
- 1 Only available when tied to a protected pole
Requires special P/N consult factory for details
 - 2 Voltage trip circuit coil not rated for continuous duty - use instantaneous delay code 10
 - 3 Contacts Rated for 20A @ 80 VDC
 - 4 440VDC Rating available in two different wiring configurations, see next page for more details
 - 5 600 VDC only available with factory installed terminal bus (see next page for more details)
 - 6 Single pole units available up to 125A, multi pole units limited to 100A Max.
(see next page for more details)
 - 7 3 Pole units must include one Auxiliary switch pole (circuit code A or G) - Requires Special Part Number. (see next page for more details)
 - 8 Screw Terminals are limited to 50A max.
 - 9 Agency approval code W only available with 440 VDC rating & circuit code B.

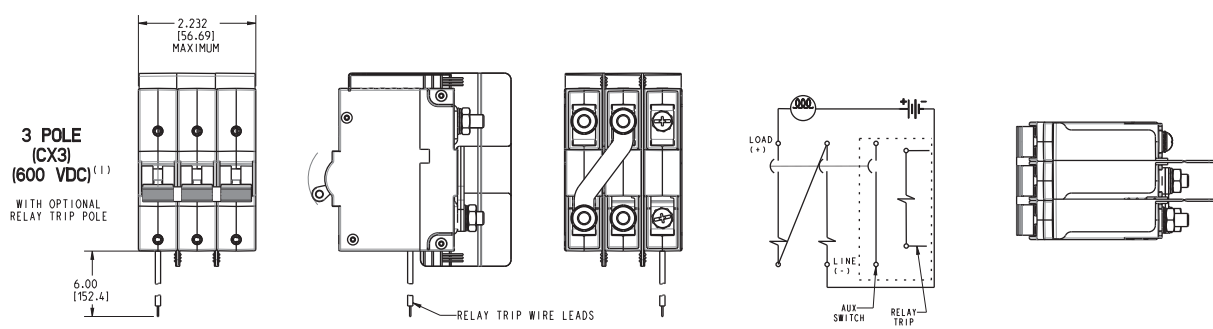
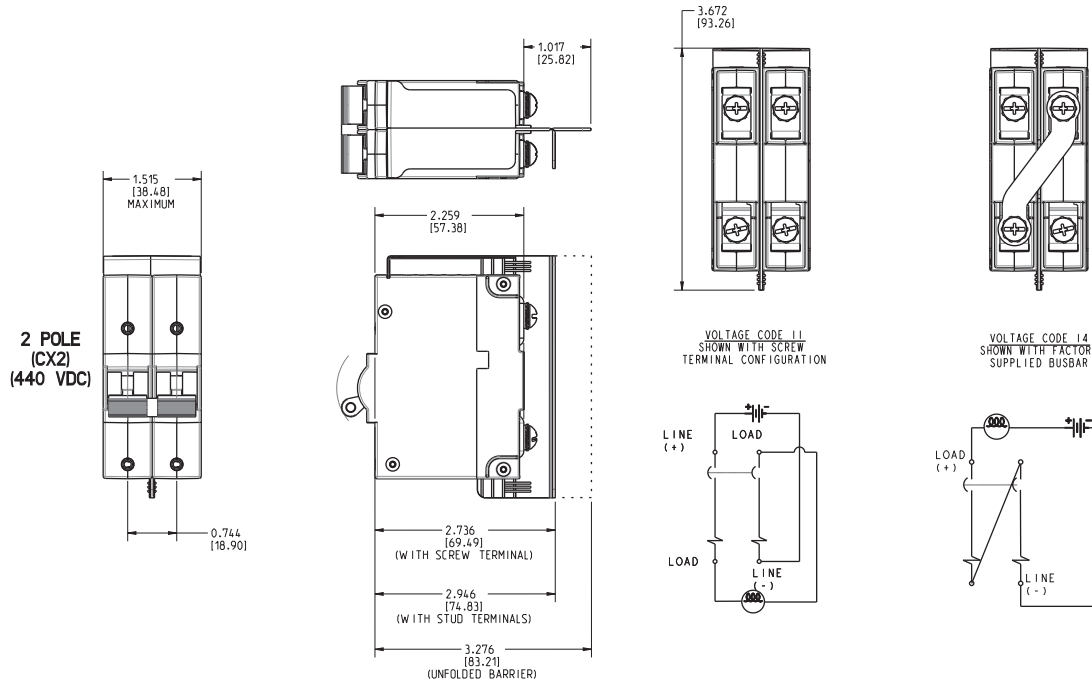
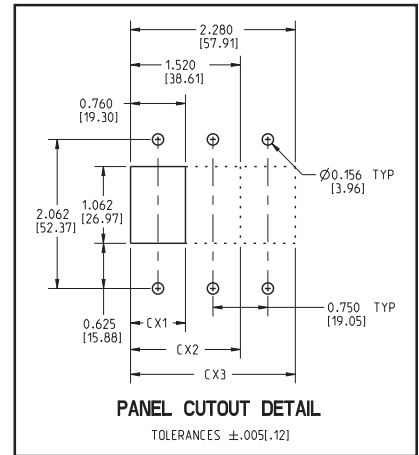
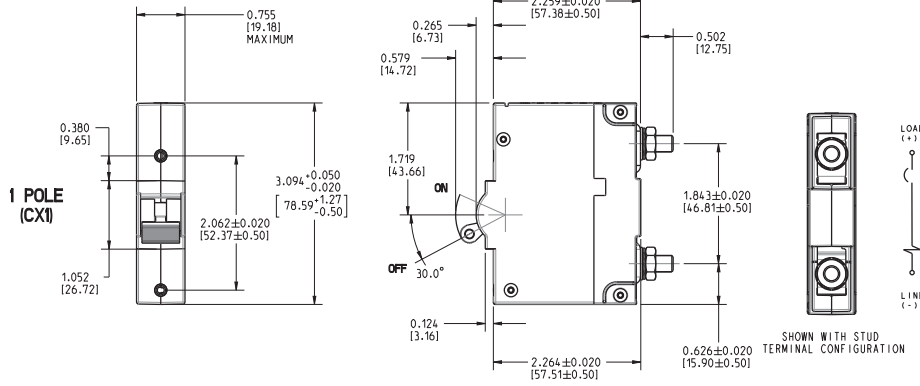

(1) 600V RATING REQUIRES MINIMUM OF 2 PROTECTED POLES

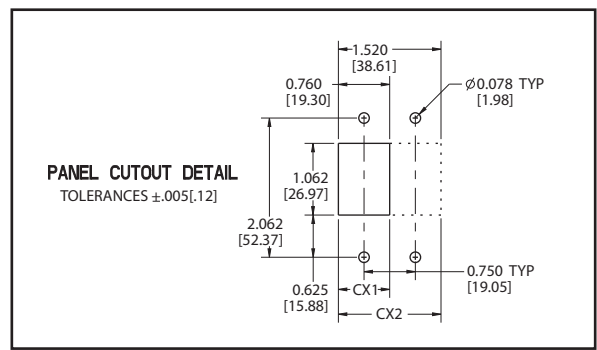
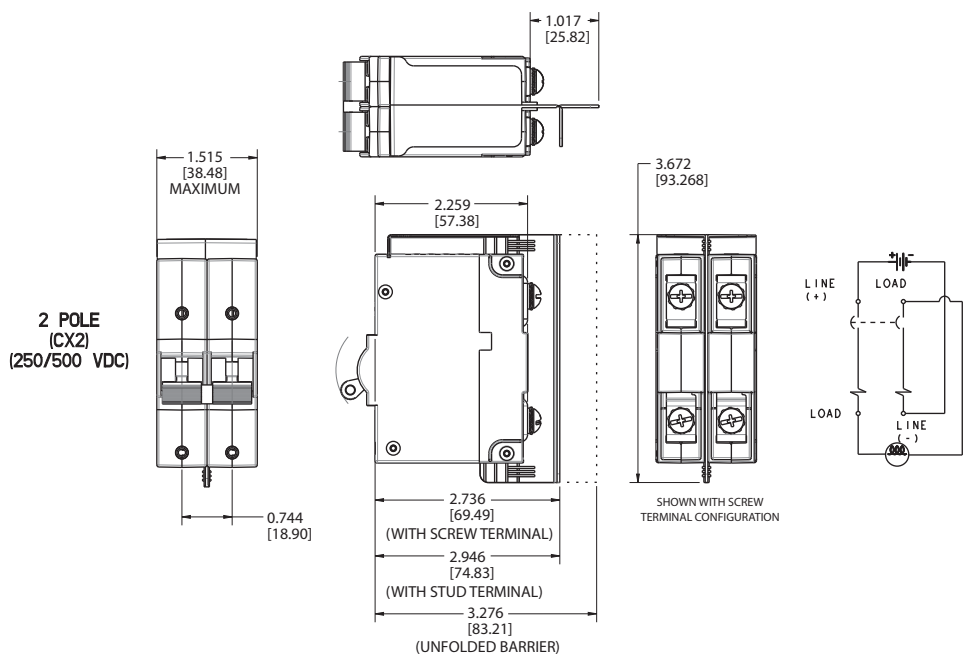
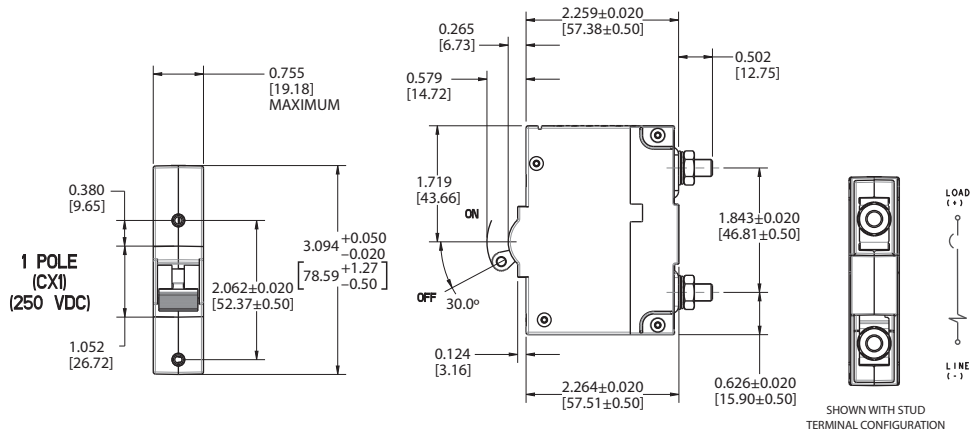

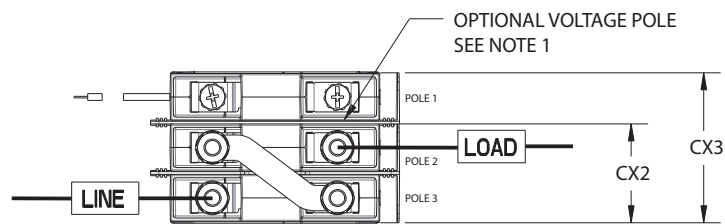
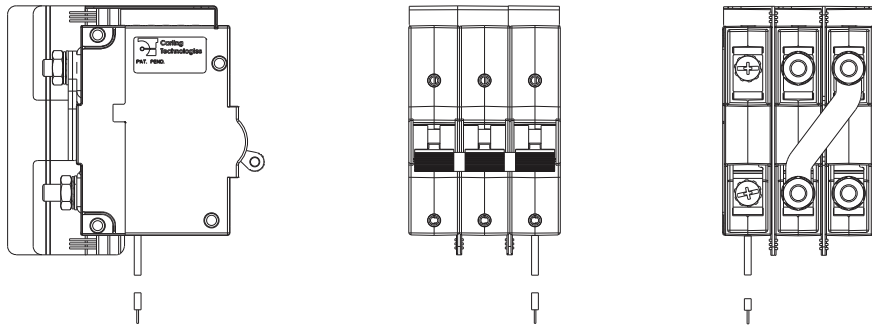

CX3 - 2 POLE SWITCH (CX2) SHOWN
WITH OPTIONAL VOLTAGE POLE
50A-100A DEVICE, 600VDC

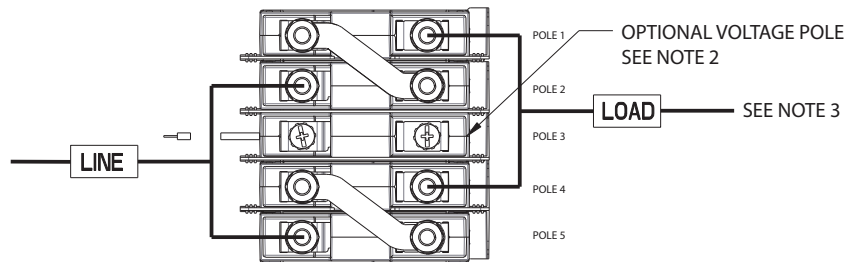

CX5 - 4 POLE SWITCH (CX4) SHOWN
WITH OPTIONAL VOLTAGE POLE
101A-175A DEVICE, 600VDC

Notes:

- 1 3 pole configuration supplied with voltage coil on pole 1. Optional location pole 3. Consult factory.
- 2 5 pole configuration supplied with voltage coil in center pole. (Pole 3)
- 3 Line & Load connections requires bus connection as shown.
Minimum cross section .127 in² (81.94 mm²)

Instantaneous - DC 10

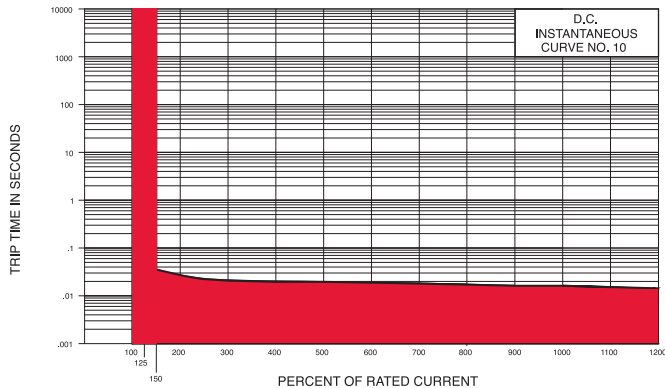

Ultrashort - DC 11

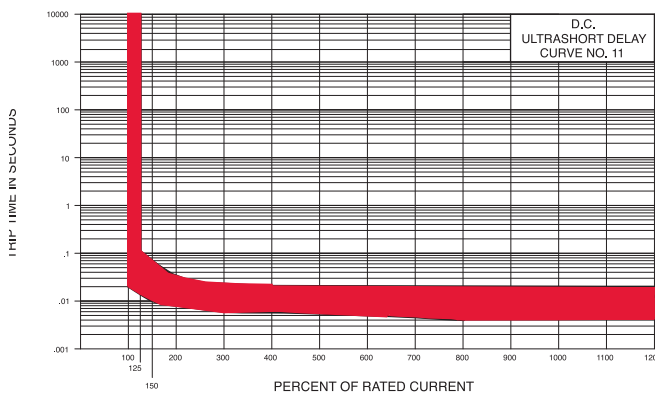

Short - DC 12

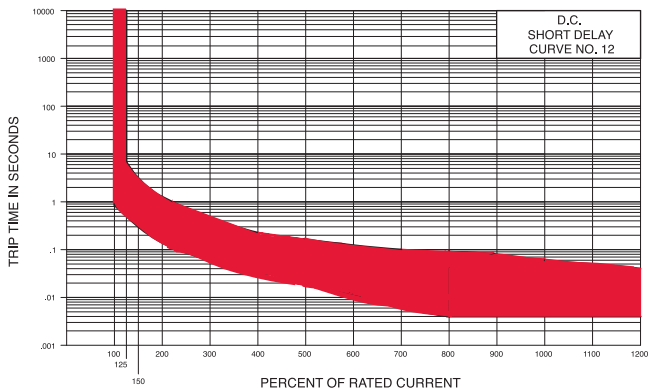

Medium - DC 14

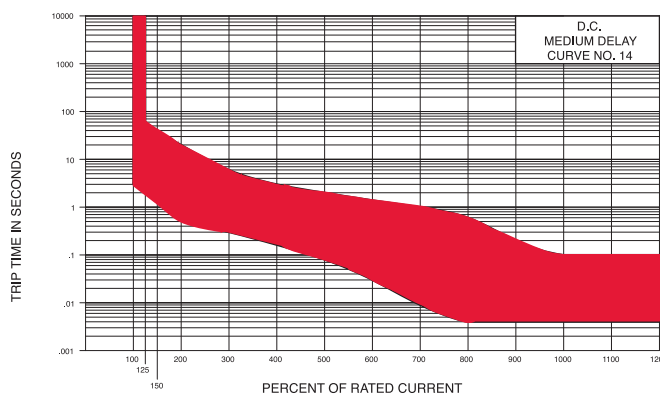

Long - DC 16

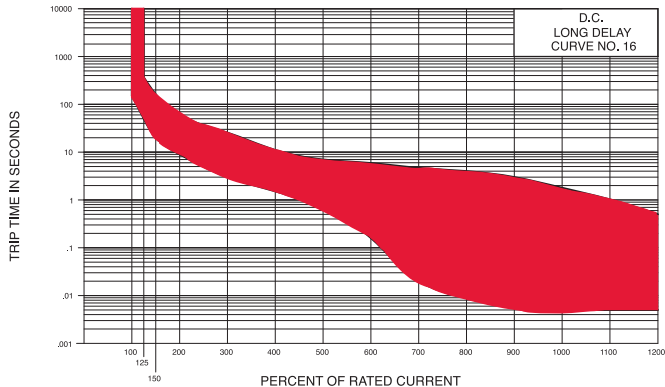

Worldwide Headquarters

Carling Technologies, Inc.
60 Johnson Avenue • Plainville, CT 06062
Phone: (860) 793-9281 • Fax: (860) 793-9231
Email: sales@carlingtech.com • www.carlingtech.com

East Region Sales Office, CT • ersm@carlingtech.com
Midwest Region Sales Office, IL • mrsm@carlingtech.com
West Region Sales Office, CA • wrsm@carlingtech.com

Asia-Pacific Headquarters

Carling Technologies, Asia-Pacific Ltd.,
Kowloon, Hong Kong
Int + 852-2737-2277 • Fax: Int + 852-2736-9332
Email: sales@carlingtech.com.hk

Shenzhen, China • shenzhen@carlingtech.com
Shanghai, China • shanghai@carlingtech.com
Pune, India • india@carlingtech.com
Kaohsiung, Taiwan • taiwan@carlingtech.com
Yokohama, Japan • japan@carlingtech.com

Europe / Middle East / Africa Headquarters

Carling Technologies LTD
4 Airport Business Park, Exeter Airport,
Clyst Honiton, Exeter, Devon, EX5 2UL, UK
Int + 44 1392-364422 • Fax: Int + 44 1392-364477
Email: ltd.sales@carlingtech.com

GmbH, Germany • gmbh@carlingtech.com
SAS, France • sas@carlingtech.com

REV_CB_CX_06_2013



Carling Technologies™

Innovative Designs. Powerful Solutions.

innovative designs. powerful solutions.